

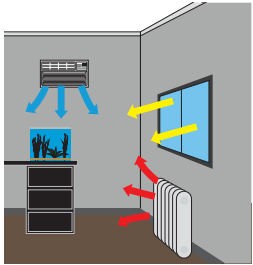

Mirage

50/45/40/31

Hints & Tips For Best Results



Consider where you are going to place the aquarium. Avoid direct sunlight and areas that experience large temperature fluctuations such as near heaters or air conditioners.

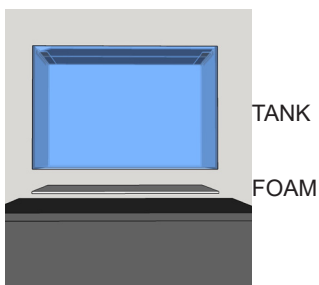

Always place the sheet of foam provided between the aquarium and the surface to absorb any irregularities. Failure to do so may result in damage to the aquarium.

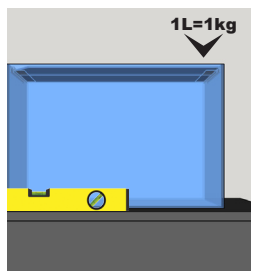

Place the aquarium on a level surface strong enough to support the weight of the aquarium, all equipment, substrate, ornaments and water in the aquarium. Note that water is heavy (1kg per litre).

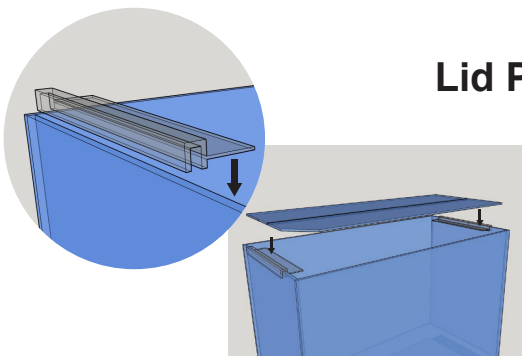

Lid Placement

Place lids on lid support as shown

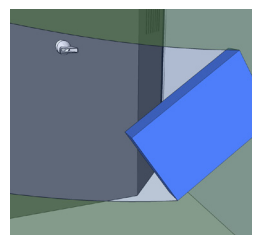

Cleaning and Maintenance

Use an algae scraper* and gently clean the inside of the aquarium.

DO NOT use any household/cleaning chemicals use only products made for aquarium use.

* Sold Separately



Children should be supervised when using this item.



Aqua One 1 Year Guarantee

Mirage

50/45/40/31

Aqua One Customer Care

Thank you for choosing this Aqua One product.

Your Aqua One product is covered for parts and labour for 1 year from the date of purchase as detailed in the terms of the guarantee below. For any inquiries or concerns regarding this product or any of our products, please do not hesitate to contact your local Aqua One Retailer or visit Aqua One Customer Care online in your country of purchase via the websites listed below.

Australia: www.aquaone.com.au New Zealand: www.aquaone.co.nz United Kingdom: www.aquaone.co.uk
All other countries: www.aquaone.com.au

Australian Consumer Law.

In Australia the Aqua One guarantee applies in addition to the guarantees that can not be excluded under the Australian Consumer Law. You are entitled to a replacement or refund for a major failure and for compensation for any other reasonably foreseeable loss or damage. You are also entitled to have the goods repaired or replaced if the goods fail to be of acceptable quality and the failure does not amount to a major failure.

About this Guarantee

The Manufacturer or Distributor, of Aqua One goods, is collectively known herein as "Aqua One". Please refer to contact details for Aqua One below or on the applicable Aqua One website. Any product that is covered by its own guarantee (as enclosed with the product) is subject to the conditions of that guarantee.

The benefits given to the purchaser, under guarantee, are in addition to all other statutory rights and remedies which the purchaser has in respect of products under legislation in the applicable country of purchase. This guarantee shall not affect any such rights and should be read subject to such legislation.

Terms and conditions of your Aqua One Guarantee

1. The Aqua One guarantee becomes effective from the date of purchase.
2. You must provide the proof of purchase before any repair or replacement of your Aqua one product is considered when requesting a guarantee claim.
3. All products subject to guarantee claim should be prepared for transportation in the original packaging or other comparable packaging which offers the same degree of protection.
4. Where products are repaired or replaced under guarantee, these products are guaranteed for the remainder of the original guarantee period, where permitted by local law.
5. Where claims on inspection reveal goods are in normal working order, Aqua One will request reimbursement of all reasonable costs incurred.
6. Where Aqua One determines the products are being used in a manner contrary to the intended purpose/use, instructions, specifications or this guarantee, Aqua One reserves the right to terminate the guarantee and will provide written notice to the purchaser.

What is covered:

1. Aqua One warrants to the purchaser, for 1 Year from date of original purchase, to repair or replace products where fault is found due to defective materials or faulty workmanship and where goods do not operate in accordance with the instructions.
2. The guarantee covers any other products as enclosed with the product unless those products are provided with their own guarantee.
3. The guarantee covers the Aquarium against gluing breakdown resulting in leakage.

What is not covered

Where permitted by local law, the following exclusions and limitations apply in regard to the guarantee:

1. Glass or Acrylic scratching, for whatever reason caused after purchase.
2. Glass breakage for whatever reason after purchase unless it is established that the breakage was caused prior to purchase.
3. Product guarantee claims where fault is due to, but not limited by a) misuse b) neglect c) abuse d) fire or flood e) normal wear and tear f) accidental breakage g) Acts of God h) vermin, insects or foreign objects.
4. Where inspections reveal the products are in normal working order.
5. Attempted repairs or modifications by unauthorised persons, including but not limited to the drilling of holes in the aquarium glass by unauthorised persons.
6. Where products are not installed, operated or maintained in accordance with Aqua One's product instructions, specifications or this guarantee.
7. Replacement of lost products, parts or components.
8. Costs associated with products transportation, removal, installation, postage or cost of insurance.
9. Any damage incurred whilst installing, transporting or moving the goods.
10. Subject to certain local statutory rights and obligations to the contrary, and this guarantee shall not affect those rights or obligations, where, to the full extent permitted by law: 1. all express and implied warranties and conditions under statute or general law, are expressly excluded and Aqua One, where permitted, will limit liability as follows and at Aqua One's option to: in regard to products either a) the replacement of goods or supply of equivalent goods b) the repair of products or the cost of replacing the products OR of acquiring equivalent products OR in regard to services either c) the re-supply of services d) the cost to re-supply services. 2. Aqua One will not be liable for any loss or damage, including consequential loss or damage either directly or indirectly, or for any incidental expenses, of any kind, and in any way whatsoever.

Aqua One may be contacted in:

Australia
Kong's (Aust.) Pty. Limited
PO Box 863, Ingleburn
1890 NSW Australia
www.aquaone.com.au

Hong Kong
Kong's Aquarium Supplies Co., Ltd
No 31, 3/F Thriving Industrial Centre
26-38 Sha Tsui Road, Tsuen Wan,
Hong Kong
www.aquaone.co.hk

New Zealand
Kong's (NZ) Limited
PO Box 15 - 183, Tauranga
3015 New Zealand
www.aquaone.co.nz

United Kingdom
Kong's (UK) Limited,
C/O Aqua Pacific UK Ltd.
PO Box 268
Romsey Hampshire, SO51 0WW
United Kingdom
www.aquaone.co.uk